

# QUATTRO INSTRUCTIONS

1.

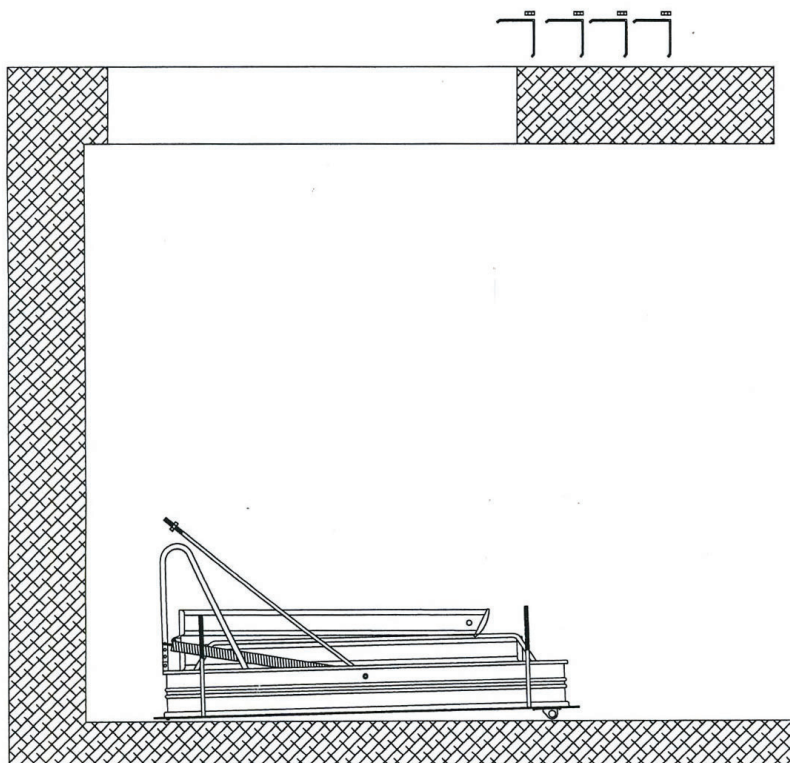

2.

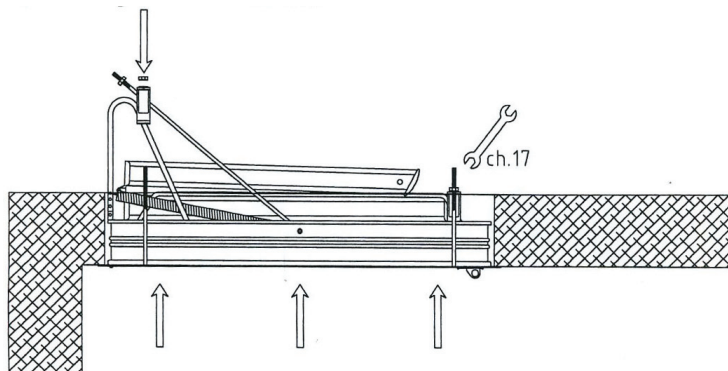



3.

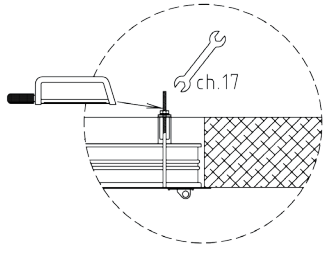
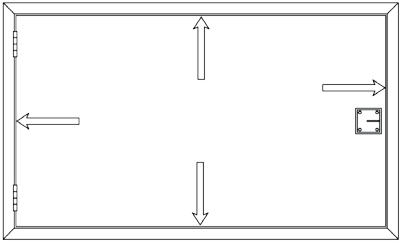

4.

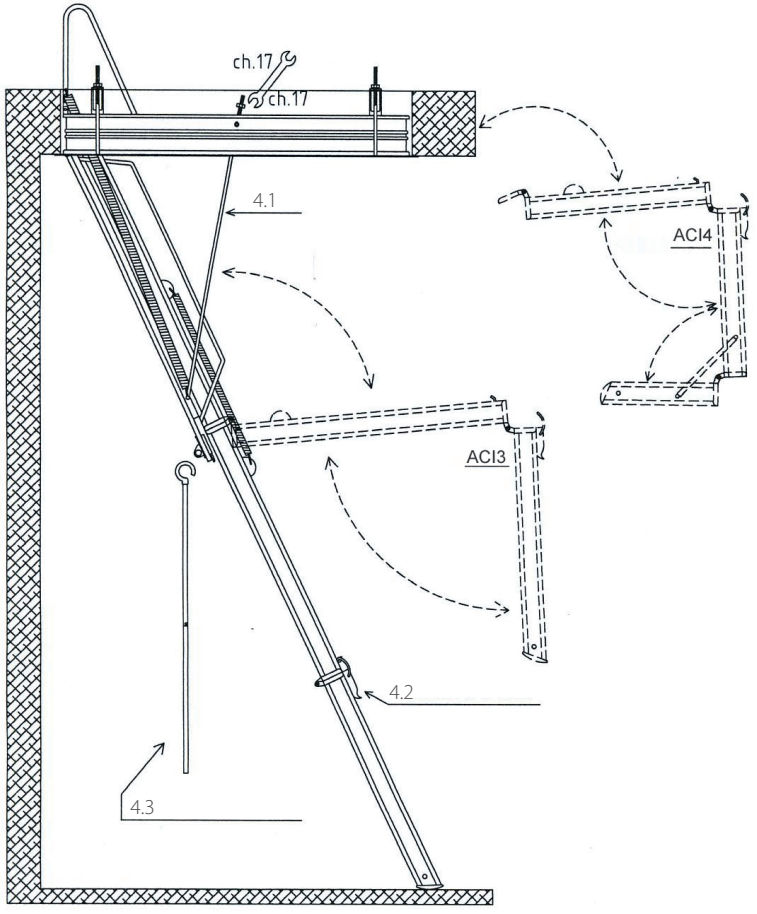

5.

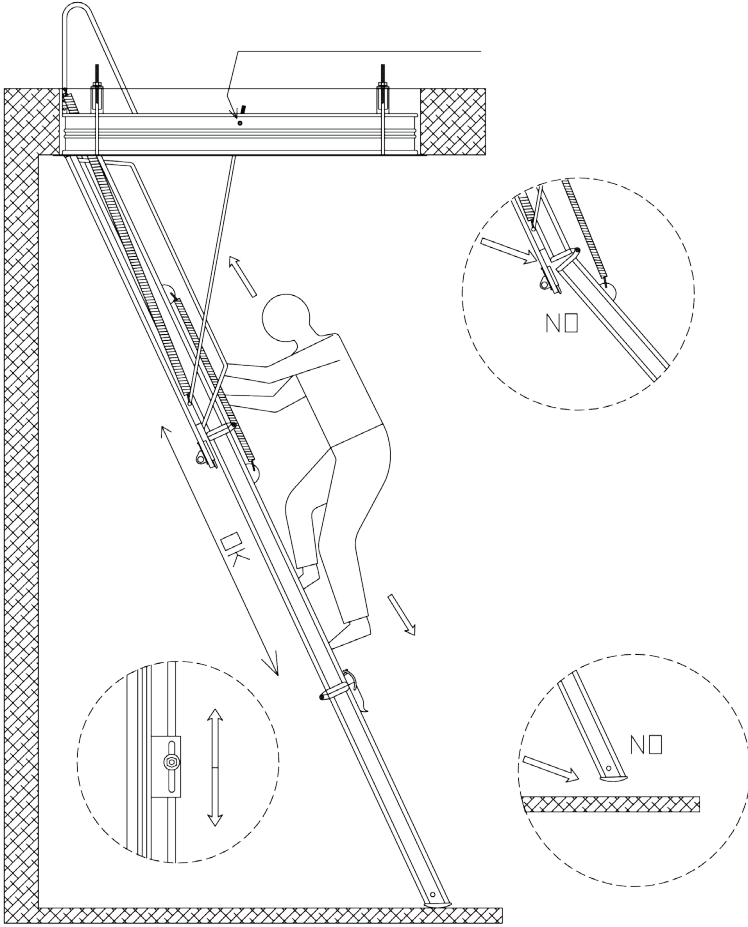

1.

Open up the packaging and remove the ladder and the operating pole (leave on the access floor). Remove the 4 top-fixing brackets with the relevant nuts and place on the loft/upper floor.

2.

By means of supports or ropes, push the ladder into the ceiling aperture from underneath. Once in place insert the drilled brackets vertically onto the 10mm threaded bars. Then fasten with the 10mm nuts and spanner (17), until the frame of the hatch box lies flush with the ceiling. Do not fully tighten the nuts at this stage

3.

Check the ladder from underneath (in its stowed position) and make sure there is a consistent, uniform space between the frame and the hatch door. If this is not the case, then you will need to make small adjustments until a uniform gap is achieved. Once correct, fully tighten the 10mm nuts.

**N.B.** It is recommended that you cut off the excess threaded rod above the lock nut.



## 4.

Use the operating pole to pull the hatch door down. Then unfold the 4 section ladder and lock them with the locking catch. Ensure the sections are perfectly aligned and that the bottom of the ladder rests firmly on the floor. If the sections are not aligned and/or the ladder does not safely rest on the floor then you must adjust the tie-rods by either tightening or loosening both 10mm nuts with the spanner (17).

4.1 = Tie-rod

4.2 = Ladder's locking catch

4.3 = Operating pole

5

## 5.

Should the ladder be adjusted for heights falling outside standard heights, in addition to adjusting the tie-rods you may need to slide the ladder up or down the hatch door. To do this you will need to loosen and then re-tighten the 8mm nuts at the side of the ladder using the spanner (13).

**N.B.** You should always be facing the ladder while climbing up and down the ladder.



<b>PROVA DI CARICO STATICO SU SCALA RETRATTILE secondo norma UNI EN 14975:2006</b>			
	PRECARICO Kg. 100	CARICO MEDIO Kg. 160	CARICO MAX APPLICATO Kg. 260 SPECIFICA UNI EN 14975:2006
TEMPO DELL' APPLICAZIONE	t = 60 Secondi	t = 60 Secondi	t = 60 Secondi (2)
CONTROLLO DIMENSIONALE	Conforme (Tab. 2 UNI EN 14975:2006)	Conforme (Tab. 2 UNI EN 14975:2006)	Conforme (Tab. 2 UNI EN 14975:2006)
STATO DELLE SALDATURE	Nessuna alterazione rilevabile	Nessuna alterazione rilevabile	Nessuna alterazione rilevabile (1)
STATO MOLLE	Nessuna deformazione rilevata	Nessuna deformazione rilevata	Nessuna deformazione rilevata
STATO STAFFE	Nessuna deformazione rilevata	Nessuna deformazione rilevata	Nessuna deformazione rilevata
TIRANTI	Nessuna rottura	Nessuna rottura	Nessuna rottura
STATO DEL GRADINO	Nessuna alterazione rilevabile	Nessuna alterazione rilevabile	Lieve deformazione del gradino Nessuna rottura o cedimento
STATO CHIUSURE	Nessuna alterazione rilevabile	Nessuna alterazione rilevabile	Nessuna alterazione rilevabile
<b>Mod. ACI SVEZIA Mod. ACI ALLUMINIO Mod. ACI TRE Mod. ACI QUATTRO</b>	<b>RESISTE</b>	<b>RESISTE</b>	<b>RESISTE</b>

(2) = Tempo di applicazione del precarico di kg. 100, t= 60 secondi come da UNI EN 14975:2006  
 (2) = Tempo di applicazione del precarico di kg. 160, t= 60 secondi come da UNI EN 14975:2006  
 (2) = Tempo di applicazione del precarico di kg. 260, t= 60 secondi come da UNI EN 14975:2006  
 (2) = Per le prove di carico arsono utilizzate masse certificate dal peso di kg. 20 ciascuna  
 (2) = PORTATA MAX TESTATA SUL GRADINO CENTRALE kg. 260  
 (1) = Qualifica di saldatori: rif. EN 287-1 ed EN 287-2 (processi manuali)  
 (1) = Qualifica degli operatori di saldatura: rif. EN 1418 (processi automatizzati)  
 (1) = Saldatori e operatori di saldatura certificati secondo normativa EN  
 (1) = rif. norme sui processi di saldatura: EN 15614-1 (acciaio) ed EN 15614-2 (alluminio)



<b>DEAD LOAD TEST ON FANTOZZI SCALE SRL LOFT LADDERS - standard UNI EN 14975:2006</b>			
	PRELOAD Kg. 100	MEAN LOAD Kg. 160	MAX APPLIED LOAD 260 Kg. UNI EN 14975:2006 STANDARD
APPLICATION t	t = 60 Seconds	t = 60 Seconds	t = 60 Seconds (2)
DIMENSIONAL CHECK	Compliant (Tab. 2 UNI EN 14975:2006)	Compliant (Tab. 2 UNI EN 14975:2006)	Compliant (Tab. 2 UNI EN 14975:2006)
WELDING STATE	No detectable alteration	No detectable alteration	No detectable alteration (1)
SPRING STATE	No distortion detected	No distortion detected	No distortion detected
BRACKET STATE	No distortion detected	No distortion detected	No distortion detected
TIE ROOFS	No failure	No failure	No failure
RUNG STATE	No detectable alteration	No detectable alteration	Slight rung distortion, No failure or yield reported
FOLDER LADDER PACK STATE	No detectable alteration	No detectable alteration	No detectable alteration
<b>ACI SVEZIA Mod. ACI ALLUMINIO Mod. ACI TRE Mod. ACI QUATTRO Mod.</b>	<b>WITHSTANDS</b>	<b>WITHSTANDS</b>	<b>WITHSTANDS</b>

(2) = Application time of the kg. 100 preload, t= 60 seconds as per UNI EN 14975:2006  
 (2) = Application time of the kg. 160 preload, t= 60 seconds as per UNI EN 14975:2006  
 (2) = Application time of the kg. 260 preload, t= 60 seconds as per UNI EN 14975:2006  
 (2) = For load tests approved weights were used, weighing 20 kg. each  
 (2) = MAX LOAD TESTED ON THE MIDDLE RUNGS: kg. 260  
 (1) = Welders' qualifications: ref. EN 287-1 and EN 287-2 (manual procedures)  
 (1) = Welding operators' qualifications: rif. EN 1418 (automated procedures)  
 (1) = Welders and welding operators approved in compliance with EN standards EN  
 (1) = Ref. to standards on welding procedures: EN 15614-1 (steel) ed EN 15614-2 (aluminium)



<b>ENSAYO DE CARGA ESTÁTICA EN ESCALERA ESCAMOTEABLE DE TECHO FANTOZZI SCALE SRL - norma UNI EN 14975:2006</b>			
	PRECARGA Kg. 100	CARGA MEDIA Kg. 160	CARGA MÁX APLICADA Kg. 260 NORMA UNI EN 14975:2006
APLICACIÓN t	t = 60 Segundos	t = 60 Segundos	t = 60 Segundos (2)
CONTROL DIMENSIONAL	Conforme (Tabla 2 UNI EN 14975:2006)	Conforme (Tabla 2 UNI EN 14975:2006)	Conforme (Tabla 2 UNI EN 14975:2006)
ESTADO SOLDADURAS	Ninguna alteración detectable	Ninguna alteración detectable	Ninguna alteración detectable (1)
ESTADO MUELLES	Ninguna deformación detectada	Ninguna deformación detectada	Ninguna deformación detectada
ESTADO PIEZAS DE FIJACIÓN	Ninguna deformación detectada	Ninguna deformación detectada	Ninguna deformación detectada
TIRANTES	Ninguna rotura	Ninguna rotura	Ninguna rotura
ESTADO PELDAÑO	Ninguna alteración detectable	Ninguna alteración detectable	Lieve deformación del peldaño Ninguna rotura o hundimiento señalado
ESTADO CIERRES PAQUETE DE ESCALERA	Ninguna alteración detectable	Ninguna alteración detectable	Ninguna alteración detectable
<b>Mod. ACI SVEZIA Mod. ACI ALLUMINIO Mod. ACI TRE Mod. ACI QUATTRO</b>	<b>RESISTE</b>	<b>RESISTE</b>	<b>RESISTE</b>

(2) = Tiempo de aplicación de la precarga de kg. 100, t= 60 segundos de acuerdo con la norma UNI EN 14975:2006  
 (2) = Tiempo de aplicación de la precarga de kg. 160, t= 60 segundos de acuerdo con la norma UNI EN 14975:2006  
 (2) = Tiempo de aplicación de la precarga de kg. 260, t= 60 segundos de acuerdo con la norma UNI EN 14975:2006  
 (2) = Para los ensayos de carga se han utilizado pesas certificadas de 20 kg. cada una  
 (2) = CAPACIDAD MÁXIMA PROBADA EN EL PELDANO CENTRAL 260 kg.  
 (1) = Normas de referencia sobre la cualificación de los soldadores: rif. EN 287-1 ed EN 287-2 (procesos manuales)  
 (1) = Normas de referencia sobre la cualificación de los operadores de soldadura: rif. EN 1418 (procesos automatizados)  
 (1) = Soldadores y operadores de soldadura certificados según las normas EN  
 (1) = Normas de referencia sobre los procesos de soldadura: EN 15614-1 (acero) ed EN 15614-2 (aluminio)

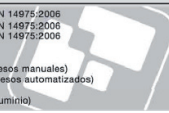

*I dati e le misure non sono impegnative la ditta si riserva di appotare modifiche in qualsiasi momento.  
Technical information is purely indicative. The firm reserves the right to make changes without prior notice.*



**fantozzi scale**  
un passo avanti one step further <sup>s.p.a.</sup>

Via Roma,1  
41016 Novi di Modena (MO) - Italia  
Tel: +39 059 676193  
Fax: +39 059 677347  
info@fantozziscale.com  
www.fantozziscale.com