

Fitting of Riser Bars

(Juliette and Blackjack Spiral Stairs)



The riser bar is of universal fitting and will probably need cutting to length. It should be fitted as in the diagram, to prevent the passage of a 100mm diameter at any point between the two treads.

The fixing screw at position B should typically be placed 80mm from the inner end of the tread.

Models Juliette & Blackjack

Offer riser bar horizontally to rear of tread.

Mark off its length and the drill position at point A. Wrap the masking tape around the riser bar and cut to length with fine tooth hacksaw.

Tape baluster, lightly centre punch and drill through inner face with 3mm drill.

Fix plastic tube plug at position A by pushing a self tapping screw through its centre and screwing firmly into the baluster hole.

Push end of infill bar onto fixed plastic plug and screw its other end into the rear of tread at position B using no. 8 x 1 3/4" countersink screw and cup.

Model Blackjack only

Inner end B is fitted as above.

Outer end A is as Diagram. 1 only where balusters are fitted. Where treads abut a wall, fit as shown in Diagram 2.

N.B. Start cutting and fixing the longer riser bars first. This enables any mistakes to be relegated to the shorter treads.

Cut section of 32mm x 32mm timber provided exactly to fit in between treads as seen in Diagram 2.

Drill 5mm holes where indicated in section 11 of main instructions. Pilot drill centrally and secure section using no. 10 x 2" screws, then fix riser bar as per instructions.

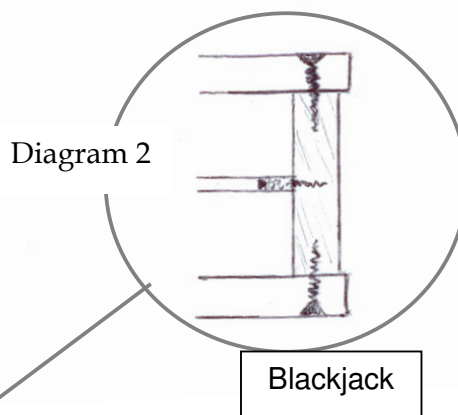
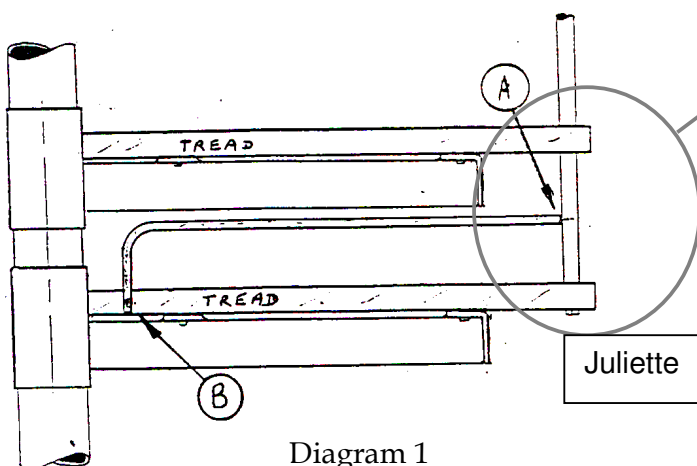

Diagram 1

Units C & D, Ford Lane Industrial Estate
Arundel, West Sussex, BN18 0DF
Tel: 0845 676 0704
Fax: 0845 676 0705
Email: sales@loftcentre.co.uk
[http:// www.loftcentre.co.uk](http://www.loftcentre.co.uk)