

Installation Instructions for Junior Concertina Ladder

Please read this guide carefully and follow the instructions before fixing the unit to your application.

Please Note: The Junior ladder is not to be used for external use. By adapting the unit or improper use will have an effect on the manufacturer's warranty. The ladder must only be used after it has been completely installed, all adjustments have been made and it's standing safely on the floor level.

Diagram 1

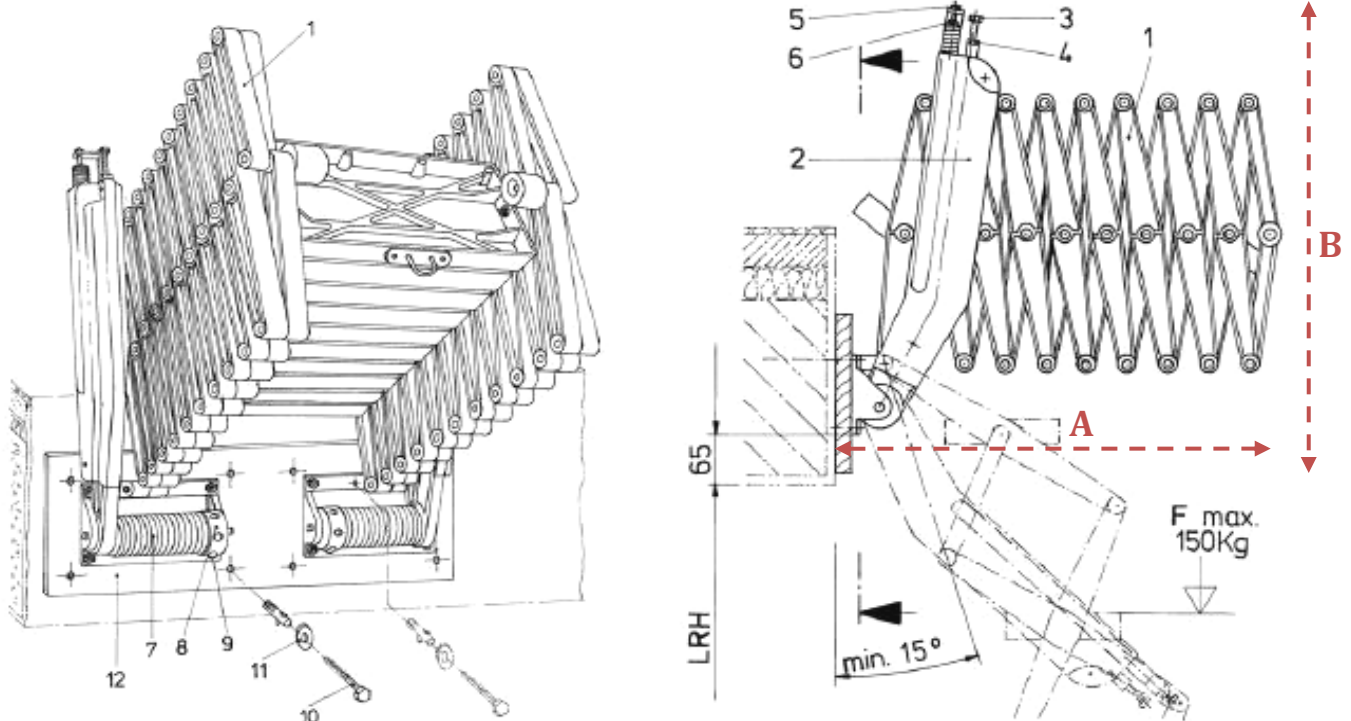

LRH (Floor to Ceiling Height) mm	No. of Treads	Closed length of Unit (A) mm	Closed height of Unit (B) mm
2200-2500	9	460	580
2500-2790	10	500	590
2790-3090	11	550	600
3090-3390	12	580	620

1. Concertina Stair
2. Operating Arm
3. Machine Screw M8
4. Nut M8
5. Machine Screw M6
6. Nut M6
7. Main Spring
8. Spring Roller
9. Rivet \varnothing 10mm
10. Fixing Screw
11. Washer
12. Timber backboard

Installation (with timber backboard) – Refer to Diagram 1 for components

The Junior Concertina ladder is supplied with an attached timber backboard (12) measuring 580mm (W) x 200mm (H). Before fitting the timber backboard to the loft opening the joist height should measure at least 125mm. If this is not the case then it is recommended that this be increased with the use of additional timber material securely fixed to the joist (Fig. 1 & 2). Ideally it is preferred that the joist height measures 200mm the same as the timber backboard. This is due to the fact that the unit is classed as a heavy duty product and considerable force will be exerted on all fixings so the increased joist height will make it more robust and secure.

Fig.

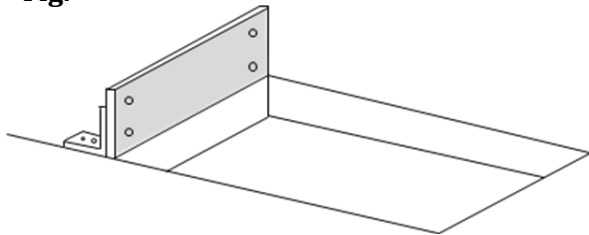
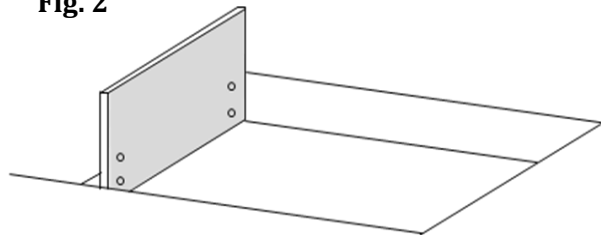
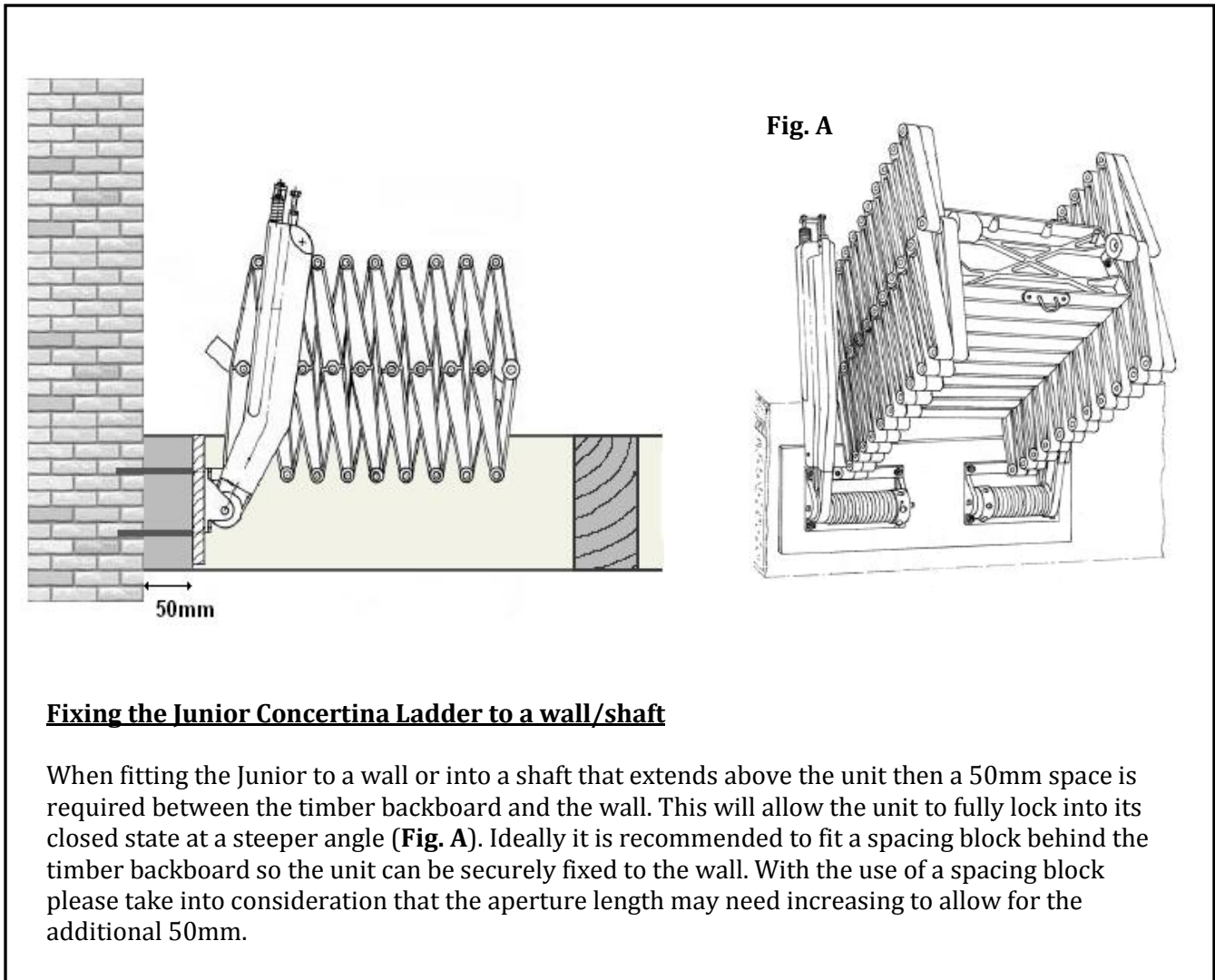

Fig. 2



To fix the timber backboard (12) to the loft opening, firstly drill between 6 to 8 holes evenly placed around the perimeter of the timber backboard. Next design a paper template of the backboard and mark on the positions of the fixing holes that you have just drilled. Position the template against the joist and mark the hole positions. Pilot holes should then be prepared to take the necessary screws (10) and washers (11). It is recommended that 100mm coach screws are used when fitting to a timber joist (these are not supplied with the unit). The unit needs to be held in place while the screws are driven home (normally a two person operation at this point of the process).

If you are fitting the Junior ladder to brick, stone or concrete then it is advised that you use rawlbolts or anchor bolts to secure the unit (these are not supplied).



Fixing the Junior Concertina Ladder to a wall/shaft

When fitting the Junior to a wall or into a shaft that extends above the unit then a 50mm space is required between the timber backboard and the wall. This will allow the unit to fully lock into its closed state at a steeper angle (**Fig. A**). Ideally it is recommended to fit a spacing block behind the timber backboard so the unit can be securely fixed to the wall. With the use of a spacing block please take into consideration that the aperture length may need increasing to allow for the additional 50mm.

★ IMPORTANT NOTE:

It is not required to make any of the adjustments (A, B or C) featured below unless it is absolutely necessary. The Junior ladder has been factory adjusted and alterations are rarely required.

[A] Adjustment of Ladders Resting Position - (Refer to Diagram 1 for components)

- Pull down the ladder to the resting position you require.
- Release the locking nut (4) and screw in the machine screw (3) until it comes in contact with the guide wheel located in the centre slot of the Operating Arm (2).
- Retighten the locking nut (4) & repeat the process on the other side.

[B] Adjustment of Ladder Descent Speed - (Refer to Diagram 1 for components)

To Slow down

- Remove plastic cover from Operating Arm (2) and loosen Nut (6).
- Start to tighten the spring by turning the Machine Screw (5), ensuring that the spring does not twist at the same time.
- The cable and pulley system should remain in line and the adjustment of both springs should be equal on both sides of the Junior ladder.
- The Nut (6) can now be retightened and the plastic covers placed back on the Operating Arms (2).

To speed up

- Follow the above list of procedures, however the springs should be loosened on each side of the ladder, instead of tightening them.

[C] Adjustment of the Main Springs – (Refer to Diagram 1 for components)

This procedure is only necessary if the ladder is not supported by the Main Springs when it is situated in its closed position.

★ WARNING – The Main Springs are under high tension and special care should be taken when adjusting them.

- Maneuver the ladder into its closed position.
- Insert a 10mm diameter metal rod into the nearest locating hole on the Spring Roller (8).
- Start to slowly push the metal rod upwards taking the tension on the Main Spring (7), as the tension is increased the Rivet (9) at the bottom of the Spring Roller (8) will be released.
- To **Tighten** the Main Spring (7): rotate the Spring Roller (8) further upwards and insert the Rivet (9) in the next locating hole.
- To **Loosen** the Main Spring (7): allow the Spring Roller (8) to slowly rotate downwards by lowering the metal rod and then insert the Rivet (9) in the locating hole above.
- Once the Rivet (9) is securely placed in the locating hole, slowly release the tension on the metal rod and the Rivet (9) will hold the tension of the Main Spring (7) at its new position.
- The process will have to be repeated for the other Main Spring (7) on the Junior ladder.

If you are having doubts about making the Adjustments (A, B or C) and need further assistance then please don't hesitate to contact our Technical Support on 0845 676 0704

Angle adjustment of treads for the Junior to make them level

- A. Open the concertina ladder and bring into position for use.
- B. Loosen nuts (2) under the tread at each end until the tread can rotate.
- C. Position the treads so they are horizontal or as near as the toothed grips will allow tightening nut (2) as you go.

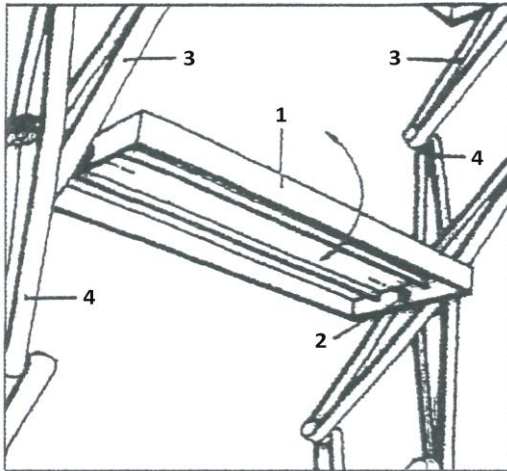

1. Tread
2. Nut M 8
3. Side element with spigots
4. Side element with holes

Safety Guide

- Always ensure the ladder is fully deployed and positioned on the floor before releasing the ladder.
- Only use the ladder when it is fully positioned on the floor level.
- Make sure the aperture is clear before relocating the ladder back to its stored position.
- When closing the ladder always maintain control with the use of the operating pole until it is in its stored position. Don't let go of the unit as it will cause the counterbalanced springs to pull it closed too quickly and this may damage the mechanism.

Maintenance Guide

The Junior ladder should be inspected and operated at least every six months and two routine procedures should be carried out during this time.

1. Lightly oil all the moving joints of the ladder to ensure a smooth operation either using very light oil or silicone spray.
2. Make sure all of the fixing screws which hold the timber backboard in place are tight.

Installing the Telescopic Handrail (Optional Component)

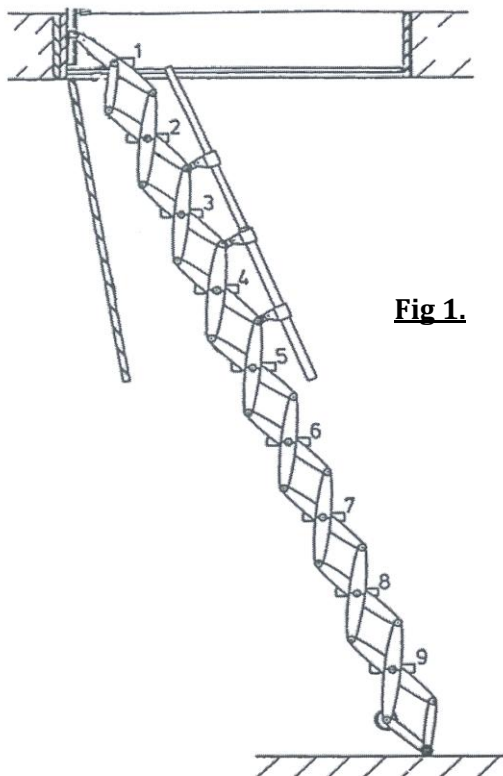

Fig 1.

Information:

- A.** The Telescopic Handrail is an optional component and is not normally supplied with the Junior ladder as standard.
- B.** The Handrail can be fitted to either the right or left hand side of the ladder (however it is dependent on which side the extended lugs are positioned).
- C.** When the Junior ladder is in its closed position, the Handrail will extend 400mm beyond the timber backboard. If the Junior is fitted to a vertical wall which extends above the ladder then a Handrail can only be installed if the upper ends of the Handrail is cut down to suit.
- D.** The hatch length must measure at least 1000mm if a Handrail is fitted. If this dimension cannot be achieved then the lower end of the Handrail tube can be cut to suit and the plastic end-plug replaced.

Fitting:

The Telescopic Handrail comes complete with all its fixings (shown in **Fig 2**).

Firstly ensure that the smaller diameter tube is fixed to top lug position on the ladder.

Next position the black nylon sleeves over the extended lugs on the ladder and push the pins through.

The clips are then placed over the pins to hold them in place.

The final procedure is to make sure the two bolts located in the upper sleeves are tight and secure.

For the Junior ladder the Handrail should be fitted to the tread positions 2, 3 & 4 (as shown in **Fig 1**).

Fig 2.

