

**3-Section Sliding Loft Ladder - Easiway**

**Packed Dimensions**

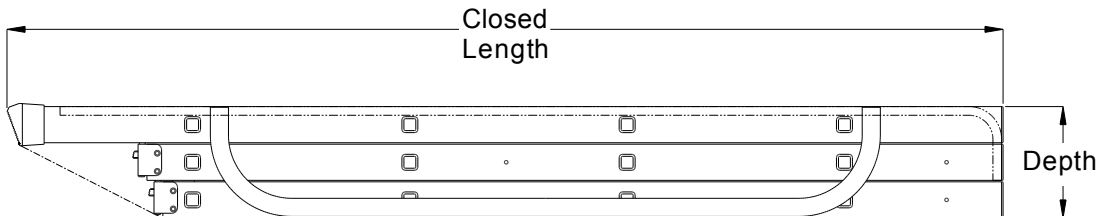
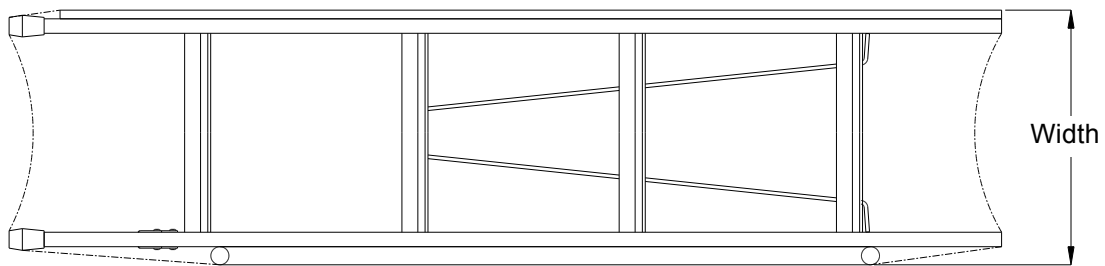

| Packaged Dimensions | Closed Length (mm) | Width (mm) | Depth (mm) | Volume (m <sup>3</sup> ) | Weight (kg) |
|---------------------|--------------------|------------|------------|--------------------------|-------------|
|                     | 1375               | 352        | 155        | 0.075                    | 7.0         |

**Technical Information**

**Materials:** Stiles and Treads - Extruded Aluminium Alloy  
 Handrails - Aluminium Alloy Tube  
 Operating Pole - Aluminium Alloy Tube with plastic lug to operate door catch.  
 Other fittings - Steel, Zinc alloy and plastic

**Duty Rating:** User and items must not exceed the maximum safe working load of 100 kg (15.7 stones)

**Classification:** Kitemarked to BS 7553 Class G (General Use) - 'For relatively low frequency and non-onerous conditions of use and storage.'

**3-Section Sliding Loft Ladder - Easiway**

**Floor to Floor Heights**

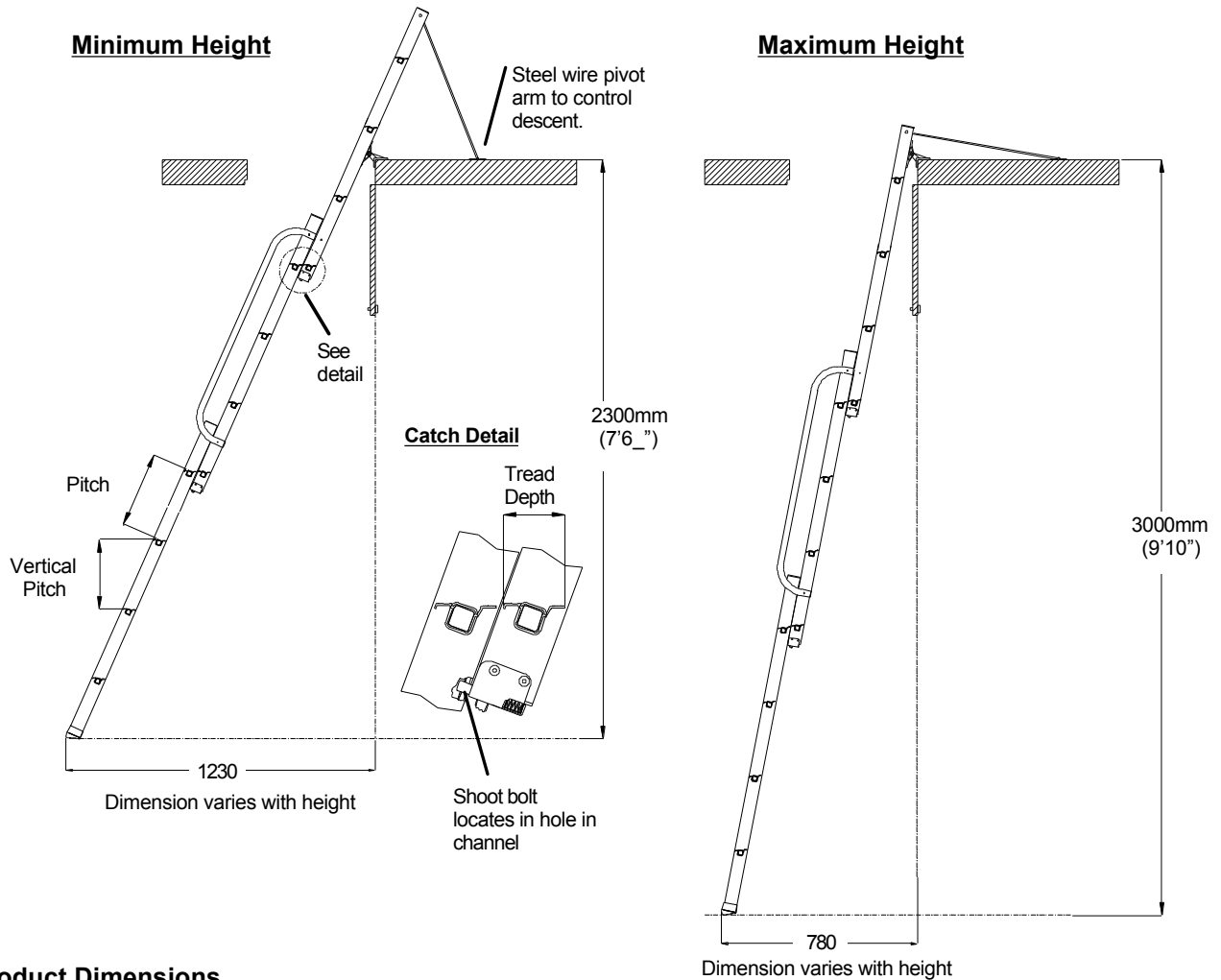

**Product Dimensions**

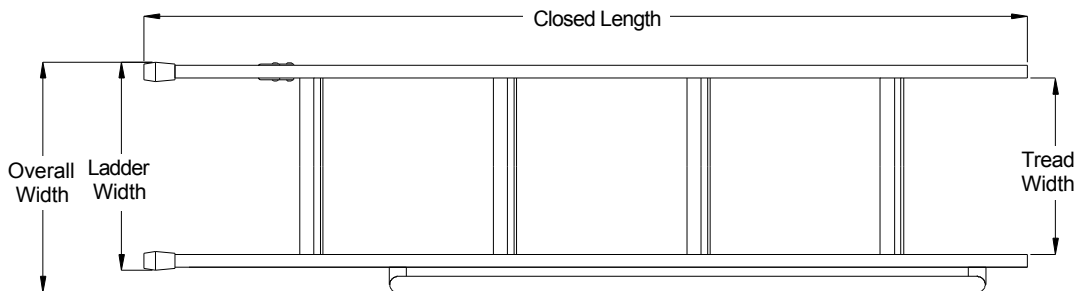

| Treads               | Total Number       | Number per Section | Width (mm)         | Depth (mm)            | Pitch (mm) | Vertical Pitch (mm) |
|----------------------|--------------------|--------------------|--------------------|-----------------------|------------|---------------------|
|                      |                    | 12                 | 4                  | 275                   | 50         | 300                 |
| Assembled Dimensions | Closed Length (mm) | Ladder Width (mm)  | Overall Width (mm) | Nominal Working Angle |            |                     |
|                      | 1375               | 325                | 360                | 70°                   |            |                     |

**3-Section Sliding Loft Ladder - Easiway**

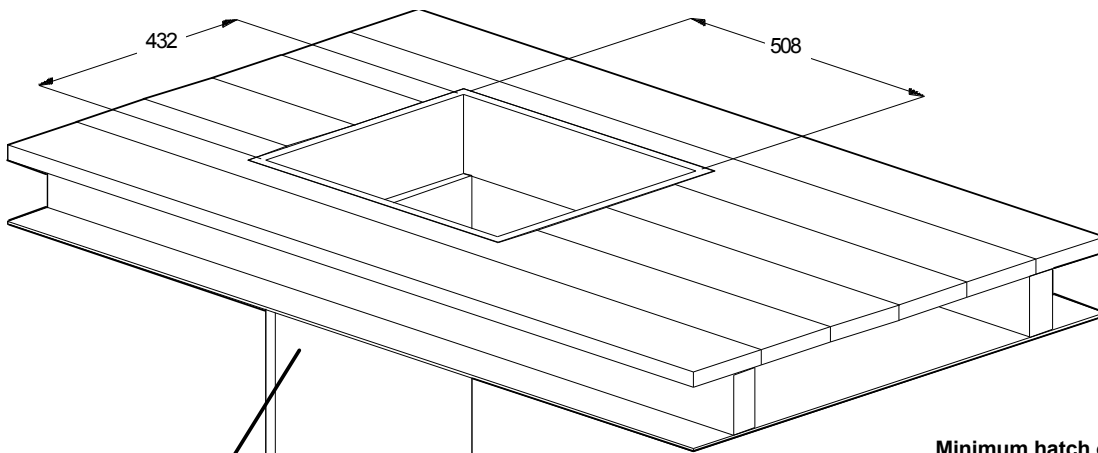

Trap door must swing down as shown. Hinges are provided.

Door catch is fitted to door. Operating pole is used to release catch.

**Minimum hatch opening required for ladder operation**

Length: 508mm  
Width: 432mm

**Arc of Clearance required**

Operating pole is used to extract ladder from loft.

Locates into hole in side of ladder

