

**2-Section Sliding Loft Ladder - Spacemaker**

**Packed Dimensions**

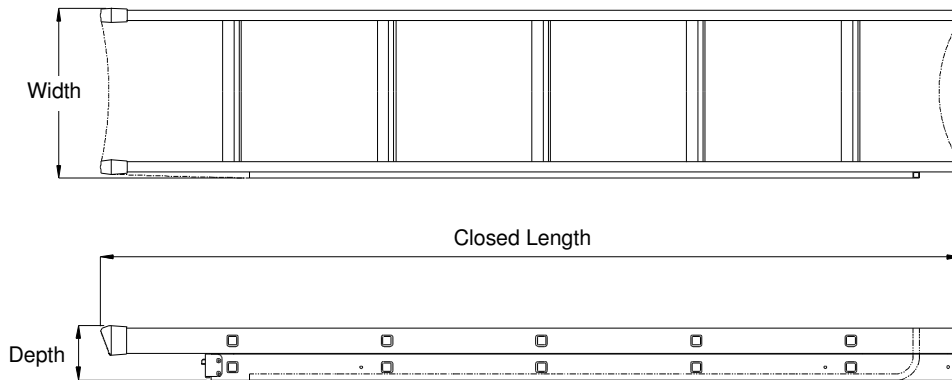

Packaged Dimensions	Closed Length (mm)	Width (mm)	Depth (mm)	Volume (m <sup>3</sup> )	Weight (kg)
	1670	331	107	0.059	5.0

**Technical Information**

- Materials:** Stiles and Treads - Extruded Aluminium Alloy  
 Operating Pole - Aluminium Alloy tube fitted with plastic lug to operate catch  
 Other fittings - Steel, Zinc alloy and plastic
- Duty Rating:** User and items must not exceed the maximum safe working load of 100 kg (15.7 stones)
- Classification :** Kitemarked to BS 7553 Class G (General Use) - *'For relatively low frequency and non-onerous conditions of use and storage.'*

**Installed Ladder at Maximum Height Setting**

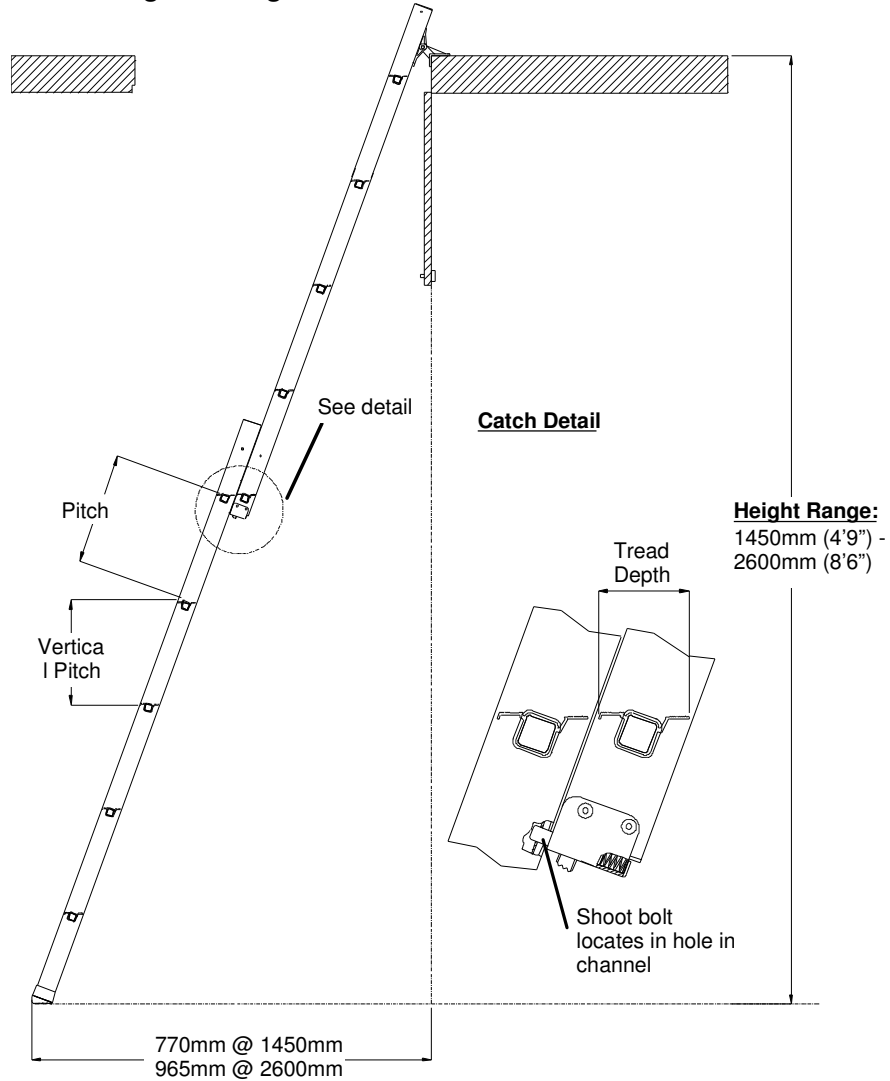

This dimension varies with height.

**Product Dimensions**

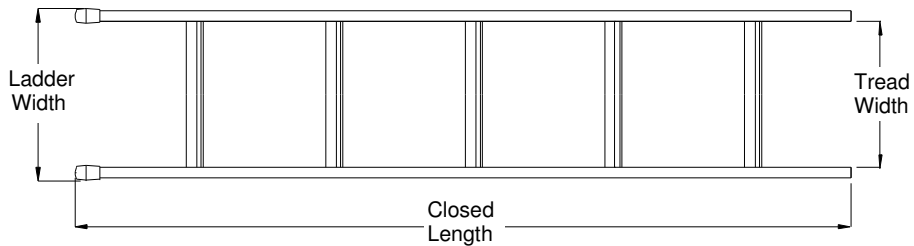

Treads	Total Number	Number per Section	Width (mm)	Depth (mm)	Pitch (mm)	Vertical Pitch (mm)
	10	5	275	50	300	282
Assembled Dimensions	Closed Length (mm)	Ladder Width (mm)	Overall Width (mm)	Nominal Working Angle		
	1665	325	N/A	70°		

**Minimum hatch opening required for ladder operation**

Length: 457mm  
Width: 406mm

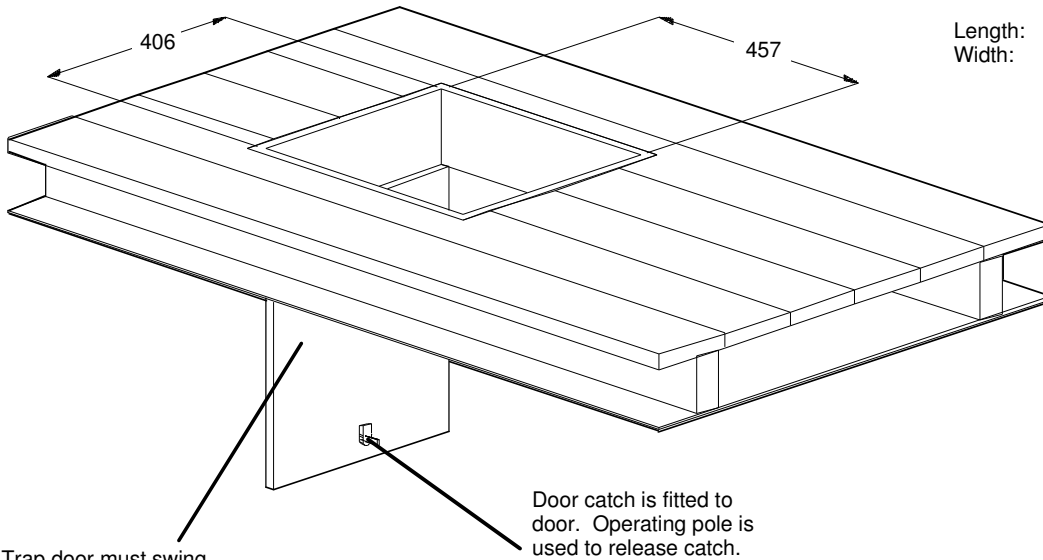

Trap door must swing down as shown. Hinges are provided.

Door catch is fitted to door. Operating pole is used to release catch.

**Arc of Clearance required**

Arc = 1670 - DIM A

Where DIM A = Hatch Length

Therefore, for a hatch length of 457mm:

Arc = 1213mm

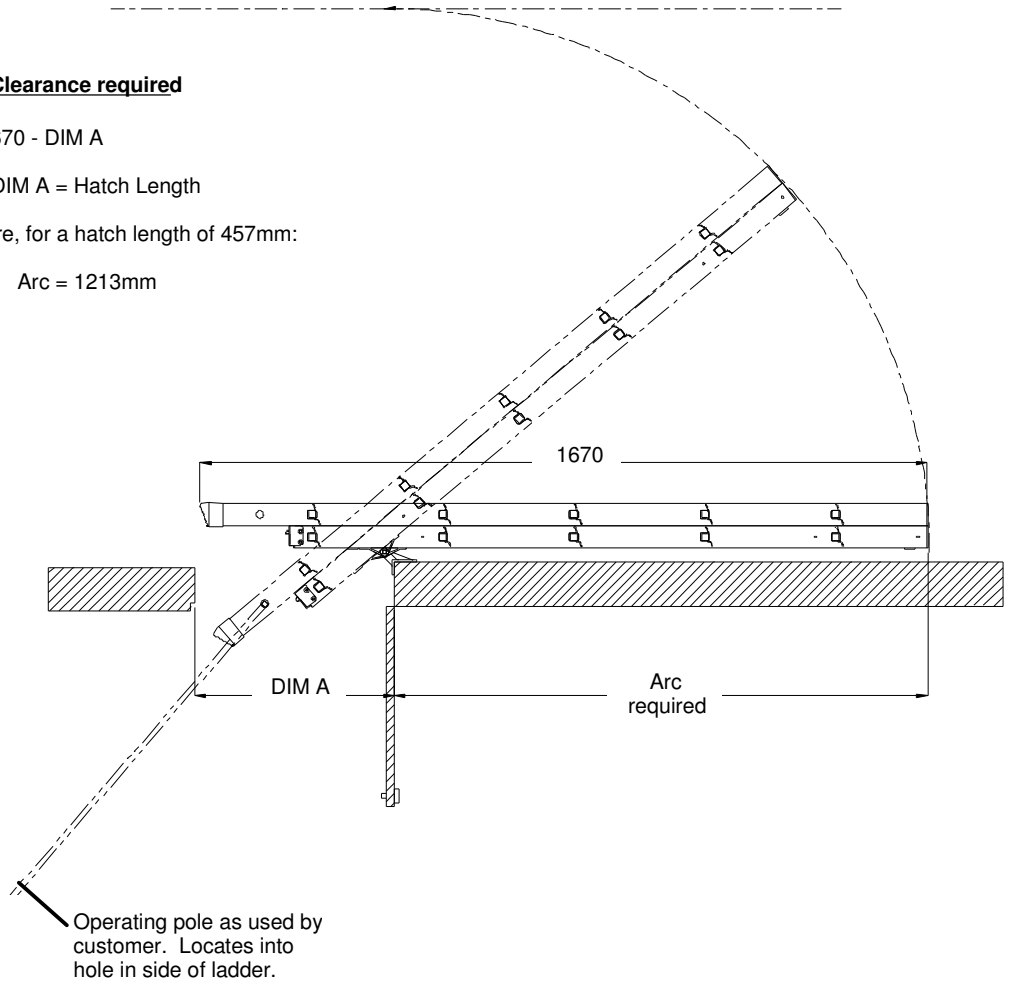

Operating pole as used by customer. Locates into hole in side of ladder.