

YAL Fitting Instructions

SAFETY WARNING

- Do not attempt to use this loft ladder until it has been properly installed and stages (1) to (5) have been completed.
- To gain access into the loft during the installation, use a ladder that extends at least 1.1m into the loft space.
- It is recommended that the installation is carried out by two people.
- Read the instructions completely before attempting to install this loft ladder and make sure they are fully understood.

1) PREPARATION OF LOFT

The loft should be boarded as shown with 1000mm x 500mm x 25mm thick ply-wood or block-board. Chip-board will **not** suffice. The hatch door must be a minimum of 19mm thick and must be hinged to swing vertically down as shown, using the two hinges fixed with 8 screws (A) supplied.

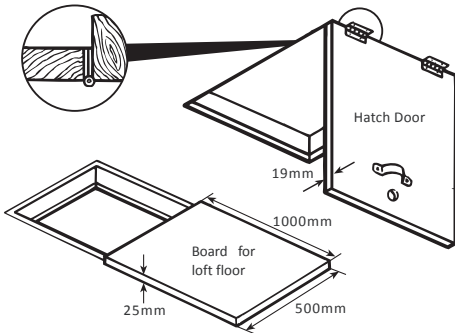

The Twist Catch Assembly and Pull Bracket should be fitted as shown.

Drill trapdoor hole.

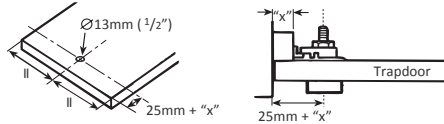

Fit pull bracket and catch plate.

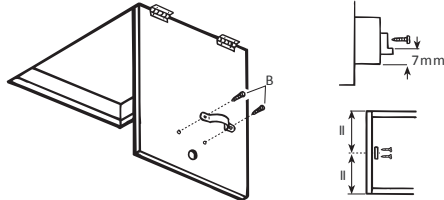

Fit twist catch

- 1) Barrel-M12 screw thread
- 2) Retainer
- 3) Catch
- 4) M12 nut
- 5) Screw
- 6) Catch Plate

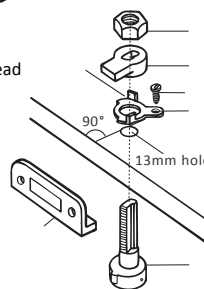

2) FITTING SIDE STOP AND CATCH PLATE

Measure the floor to loft floor height. Refer to the table to determine positions for the catch plate and side stops. Fit the catch plate and side stops as shown using 6 nuts and bolts (C). Ensure that the side stops only project slightly beyond the edge of the ladder section.

Catch Plate Position	Side Stop Position	Floor to Floor Height Range
A	E	2310mm (7'7") - 2545mm (8'4")
B	F	2545mm (8'8") - 2780mm (9'2")
C	G	2780mm (9'2") - 3015mm (9'11")
D	H	3015mm (9'11") - 3250mm (10'8")

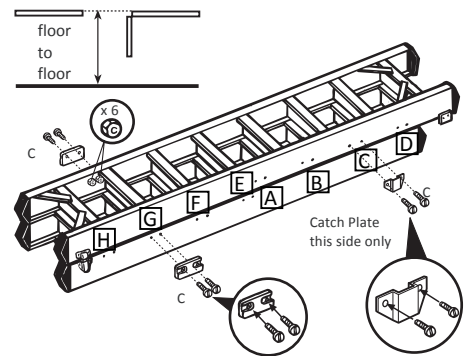

3) SECURING LADDER TO LOFT

Two people are recommended from this operation onwards – one in the loft and one on the landing. Gain access to the loft safely by using a suitable ladder.

Extend the ladder, engage the slide catch in the upper catch plate and lean it against the loft hatch making sure it is centrally positioned. Remove and retain the nuts and bolts, securing the adjusting stops in the channel on the rear edge of the upper section of the ladder (see diagram in section 5). Slide the upper hinge brackets up the channel and position on the loft floor so they are **flush** with the edge of the hatch. Mark the hole positions. Attach the upper hinge brackets to the loft floor using 8 screws (D) provided.

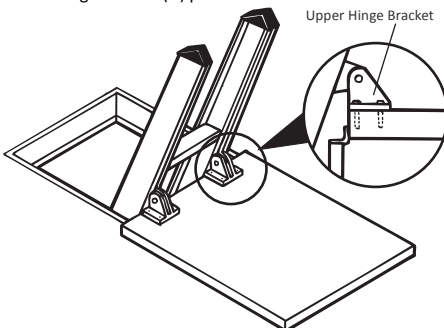

Fix the spring assembly to the loft floor as shown using 6 screws (E) provided (drill 2mm pilot holes).

NOTE: All six screws (E) MUST be fitted to ensure secure fixing.

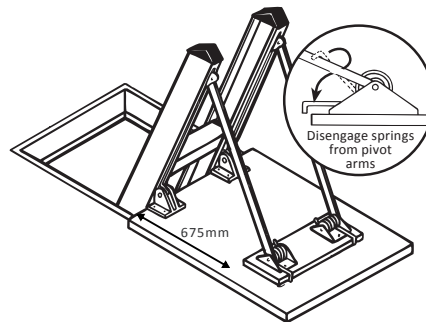

5) FIXING ADJUSTABLE STOPS

Ensure the ladder is resting firmly on the landing floor. Slide the adjustable stops down the channel in the rear edge of the upper section until they are resting on top of the upper hinge brackets. Using the nearest hole positions in the stops and ladder, refit and securely tighten the nuts and bolts that were previously removed. Count the hole positions carefully to ensure the stops are fitted at the same level on both sides of the ladder.

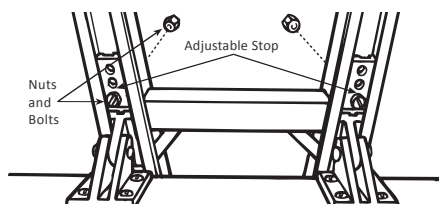

Note: The ladder can now be used safely for access into the loft to complete the installation.

6) FITTING DOOR BRACKETS

Release the side catch plate and push the lower section up until the catch re-engages with the lower catch plate. Retract the ladder into the loft. The person on the landing should temporarily shut and latch the hatch door. From inside the loft, position the ladder and the lower hinge brackets so that the brackets are resting on the inside of the hatch door. Prop the ladder in this position using a block of wood or similar.

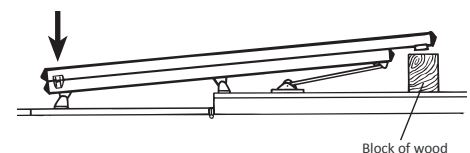

Mark the position of the fixing holes of the lower hinge brackets on the inside of the hatch door. If the loft hatch is deeper than 127mm a spacer batten should be fixed as shown to reduce the depth to less than 127mm.

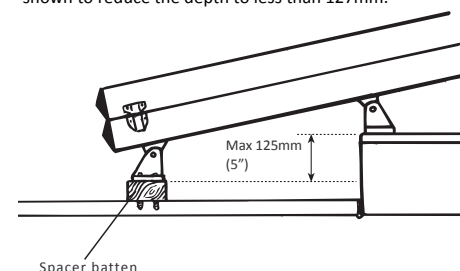

4) FITTING SPRING ASSEMBLY

Disengage springs from pivot arm as shown. Lay the spring assembly on the loft floor. Position the board of the spring assembly 675mm from the edge of loft hatch and carefully mark its position ensuring that it aligns with the centre of the ladder and parallel to the edge of the hatch.

Remove the prop and open the hatch door.
Re-engage the springs with the pivot arms.

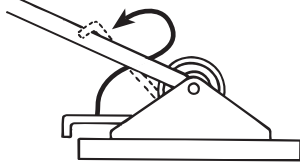

Pull down the ladder from the left until the stops engage. Release the side catch from the lower catch plate. Slide down the lower section of the ladder until the catch re-engages with the upper catch plate and the ladder is resting firmly on the landing floor.

Drill 2mm pilot holes for the lower hinge bracket fixings on the inside of face of the Hatch door. Use 8 screws (B) to secure the lower hinge brackets to the hatch.

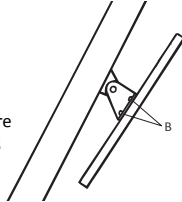

7) FITTING HANDRAILS

Fit the handrail using the 4 support brackets and nuts and bolts (F) as shown.

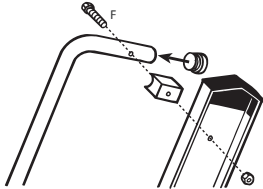

8) FITTING OPERATING POLE

Fit catch key to straight end of operating pole and square end plug to opposite hooked end.

COMPONENTS

Hinge [2] 	Pull Down Bracket [1] 	Side Stop [2] 	Catch Plate [1] 						
Handrail Support 	Handrail End Cap [4] 	Operating Pole, End plug and Catch Key [1] 							
TWIST CATCH SET		Handrail [2] 							
Catch Plate x 1 	Retaining Washer x 1 	<table border="0"> <tr> <td>(A) x 12 </td> <td>(B) x 10 </td> <td>(C) x 6 </td> </tr> <tr> <td>(D) x 8 </td> <td>(E) x 6 </td> <td>(F) x 4 </td> </tr> </table>		(A) x 12 	(B) x 10 	(C) x 6 	(D) x 8 	(E) x 6 	(F) x 4
(A) x 12 	(B) x 10 			(C) x 6 					
(D) x 8 	(E) x 6 			(F) x 4 					
Catch Barrel x 1 	Catch x 1 								
Catch Key x 1 	M12 Nut x 1 								
		TOOLS REQUIRED Crosshead Screwdriver Flat Bladed Screwdriver Bradawl Spanner: 8mm & 19mm Electric Drill Drill Bit: 2mm Tape Measure Ladder to gain access to the loft during installation							

OPERATION INSTRUCTIONS

1) To close the ladder, release the catch from the upper catch plate on the side of the ladder.

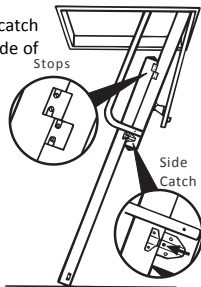

2) Push the lower section upwards until the catch re-engages with the lower catch plate. Ensure the catch is fully engaged.

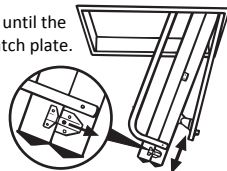

3) Put the hooked end of the operating pole into the pull down bracket on the hatch and close the hatch.

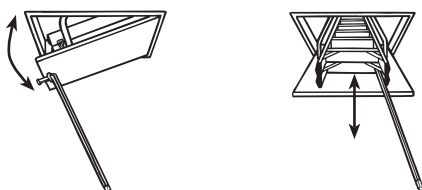

4) Engage the catch key on the other end of the operating pole with the slot in the catch barrel to push up the hatch to the fully closed position. Use the catch key to rotate the barrel until it locks into the catch plate and secures the hatch shut.

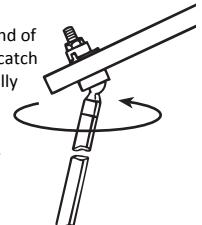

5) Opening the ladder is almost the reverse of closing. Engage the catch key on the operating pole with the slot in the catch barrel and rotate until unlocked. Engage the hooked end of the operating pole with the pull down bracket and pull down the hatch 200mm - 300mm (8" - 12").

6) Hook the operating pole into the diagonal brace below the bottom tread and pull down the ladder. When the ladder is at a convenient height it can be pulled down by hand until the stops engage. Release the side catch from the lower plate. Slide down the lower section of the ladder until the catch re-engages with the upper catch plate and the ladder is resting firmly on the landing floor.